



CREATIVE
COMPOSITES
GROUP

TUFFSPAN[®] PURLINS & GIRTS



TuffSpan[®]

CreativeCompositesGroup.com



TuffSpan Purlins & Girts

Designed for High Load & Long Span Capability

TuffSpan® Flanged Tube Beams are developed specifically for applications that require high load and long span capability plus corrosion resistance. This includes building structures, baffle wall columns and support of tank cover decking. These sections utilize a custom design that optimizes structural properties and cost through innovative use of shape, glass fiber reinforcing and manufacturing process.

TuffSpan purlins & girts are designed for the harshest environments. Utilizing an iso-polyester or vinyl resin system provides outstanding corrosion protection and is fire retardant with a flame spread rating of 25 or less. The resulting combination of corrosion resistance, non-conductivity and long span capability delivers significant end user benefits and lifetime cost savings.

STRUCTURAL PERFORMANCE

As a result of efficient design, 8F7 Flanged Tube Beams, at lesser weight and without bracing, carry more load than heavier FRP I-Beams and WF-Beams. 8F7 Flanged Tube, at 15% and 30% less weight, has greater load capacity than heavier FRP I-beams and WF Beams with bracing for single span conditions. For two span conditions, the 8F7 capacity is even greater.

EASIER INSTALLATION

The flanged tube shape provides lateral stability eliminating the need for lateral bracing, plates or angles on primary framing or sag rods. FRP components are lighter in weight and far easier to drill and cut in the field than steel components while not requiring hot work permits. These features provide time and cost savings to facilities.

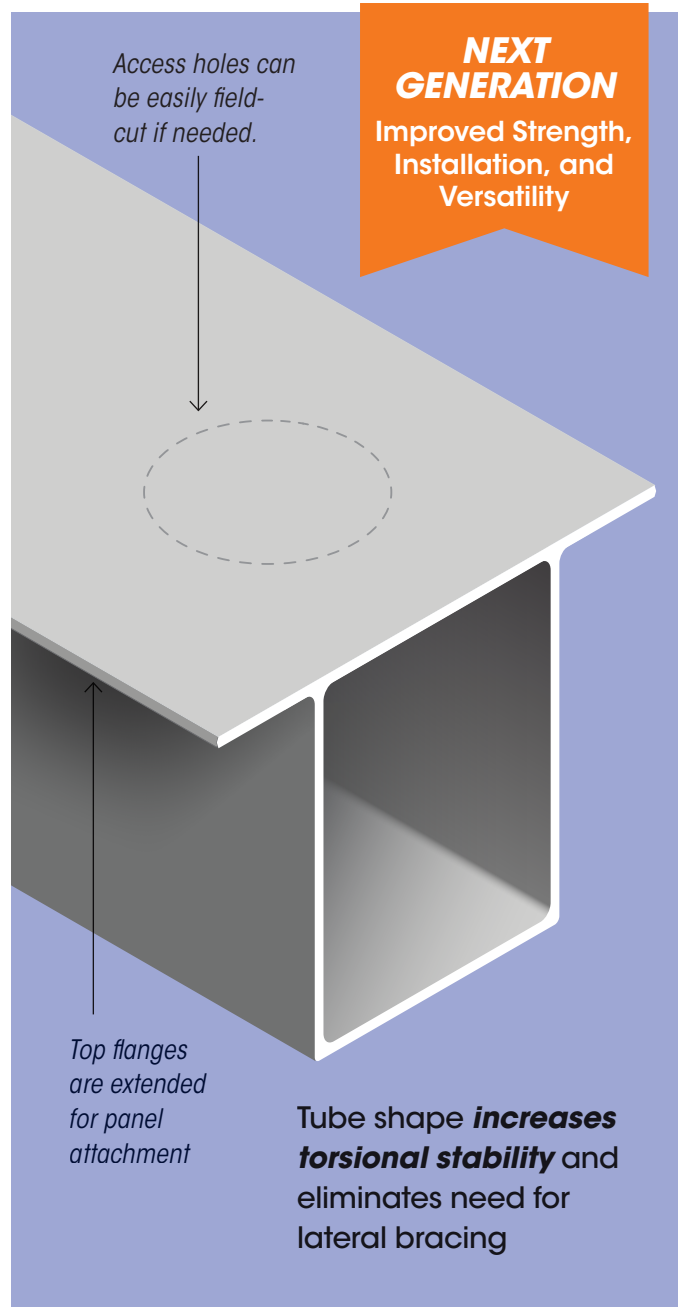

Uses

- ▶ Purlins
- ▶ Girts
- ▶ Penetration & Accessory Framing
- ▶ Walkway & Platform Framing

Features

- ▶ Corrosion Resistance
- ▶ Tubular Shape
- ▶ Fire Retardant
- ▶ Lightweight

Benefits

- ▶ Life-cycle Cost Savings
- ▶ Long Span Capability Without Lateral Bracing
- ▶ Maintenance-Free Life
- ▶ Reduced Installation Time & Costs

Complete FRP Solution

- Compatible with TuffSpan fiberglass panels for total system integration
- Stainless steel fasteners eliminate galvanic corrosion concerns
- Single-material approach minimizes maintenance issues

Exceptional Strength-to-Weight Ratio

- Up to 30% lighter than traditional FRP I-beams and WF-beams
- Capable of longer spans with superior load-bearing capacity
- Compatible with pre-engineered metal building or structural steel framing

Reduced Material Requirements

- No lateral bracing needed on roof purlins
- Fewer structural members required overall
- Streamlined construction with less potential failure points

Inverted Installation

- Typically preferred or needed when hanging sprinkler pipes or other products.
- Bolts installed through flanges which is more accessible

Superior Corrosion Resistance

- FRP material eliminates rust and degradation common in steel systems
- Long service life in harsh, corrosive environments
- SS fasteners securing FRP panels to FRP structural are less susceptible of galvanic corrosion from dissimilar metals

Simplified Installation

- No welding, plates, or clip angles required
- Tubular design eliminates the need for sag rods
- Bolt-through connections reduce installations time and hot-work construction

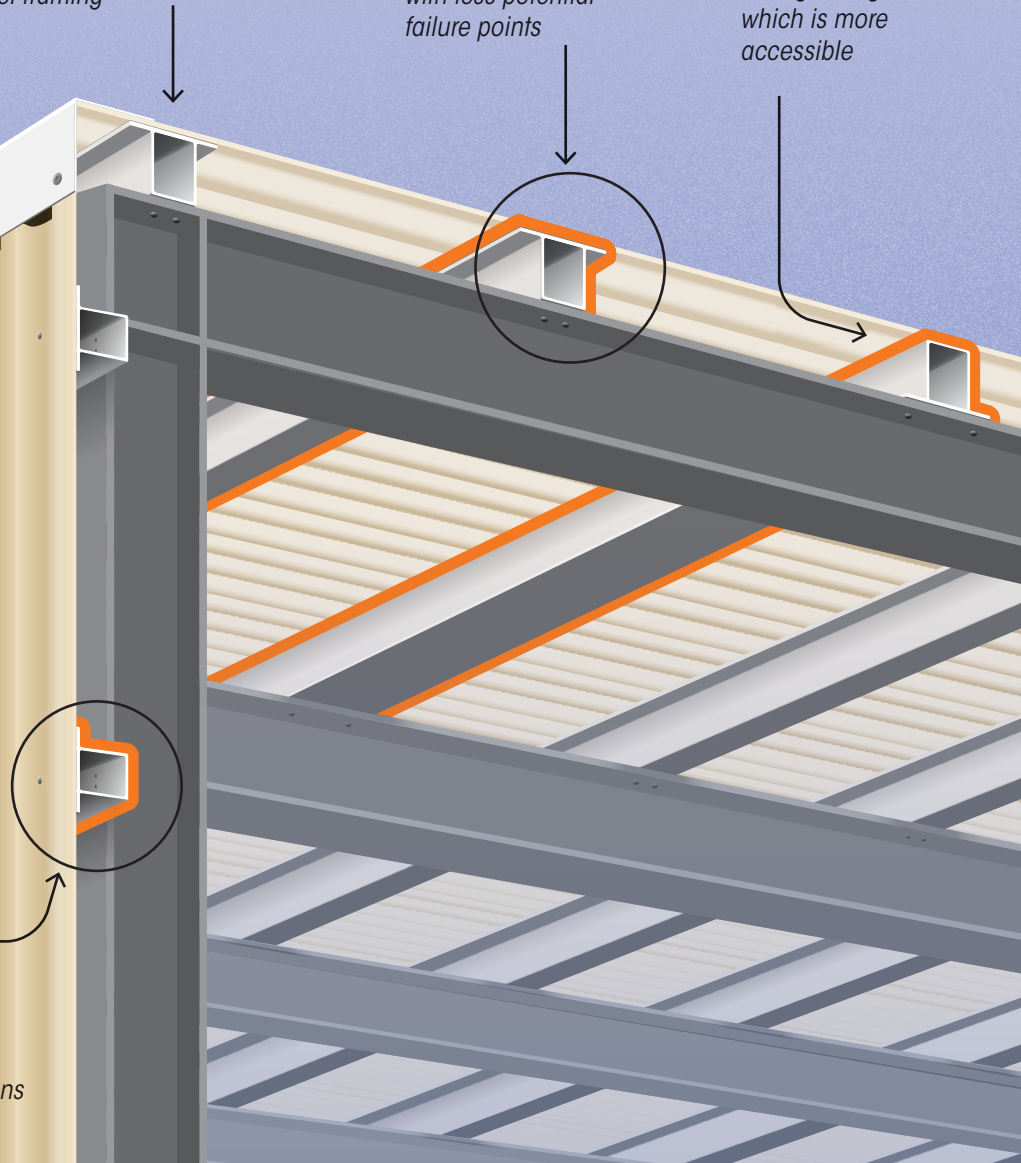

Lightweight Transportation

- Easier handling from factory to jobsite
- Reduced shipping costs
- Simplified on site installation and maneuverability

Optimized Structural Performance

- Uniform thickness throughout beam profile
- Enhanced performance in multi span vs. single span applications
- Tubular shape provides superior resistance to deflection and rolling

Customized Bill of Materials

- Made to order for precise project specifications
- Beams are designed for single or multi span conditions
- Optimized for specific bay dimensions for precise installation

8F7 Purlin / Girt

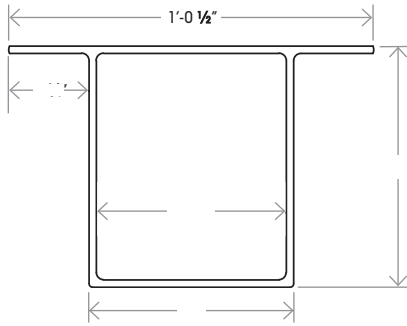

1 - Single Span; 2 - Double Span; 3 - Triple Span

Assumes no bearing failure at the base.
Assumes no local buckling.

Deflection limits based on average flexural modulus;
flexural capacity based on full scale testing.

Allowable Uniform Load (plf or lbs/ft)						
Span (ft.)	L/D = 120			L/D = 180		
	1	2	3	1	2	3
16	380	475	594	253	475	469
17	318	421	526	212	421	393
18	269	375	469	179	375	333
19	229	337	421	153	337	285
20	197	304	368	131	304	245
21	171	276	319	114	266	212
22	149	251	278	99	232	185
23	130	230	244	87	204	163
24	115	211	215	77	180	143
25	102	195	191	68	160	127
26	91	180	170	60	143	113
27	81	167	152	54	128	101
28	73	155	136	49	115	91
29	66	145	123	44	103	82
30	59	135	111	40	94	74

W = 7 plf
A = 8.82 in²
I_{xx} = 94.8 in⁴
I_{yy} = 92.6 in⁴
E = 3,841,000 psi
G = 450,000 psi
M = 456,000 in.-lbs.

1. TuffSpan 8F7 girts on a chlor alkali facility
2. TuffSpan 8F7 purlins and girts on a fertilizer storage facility
3. TuffSpan primary and secondary framing, and roofing panels on acid storage tank farm cover



Specification Fiber Reinforced Polymer Structures

PART ONE: GENERAL

1.01 Description of Work

The scope of this specification is intended to cover fiberglass reinforced plastic beams as shown on the drawings.

1.02 Performance Testing

- A. Materials shall comply with Federal and Local laws or ordinances, applicable codes, standards, and regulatory agency requirements including:
1. ASTM D638, Standard Test Method for Tensile Properties of Plastics
 2. ASTM D790, Standard Test Method for Flexural Properties of Plastics
 3. ASTM D695, Standard Test Method for Compressive Strength of Plastics
 4. ASTM E84, Standard Test Method for Surface Burning Characteristics of Plastics
- A. Structural framing shall meet performance and design criteria listed herein and indicated on the drawings.
- B. Beams shall demonstrate compliance with design criteria by full-scale, 3 Point Load Bend Test.

1.03 Design Criteria

- A. Uniform Design Loads
- | | |
|----------------|----------------|
| Wind _____ psf | Snow _____ psf |
| Live _____ psf | Dead _____ psf |
- B. Deflection Limits and Factors of Safety
- | | |
|----------------|-----------------------|
| Roof Purlins: | L/D = 180; FOS = 2.5 |
| Wall Girts: | L/D = 180; FOS = 1.88 |
| Primary Beams: | L/D = 240; FOS = 2.5 |
- * It is suggested to contact Enduro for primary beam design.*

PART TWO: PRODUCTS

2.01 Materials

- Structural shapes shall be TuffSpan as manufactured by Enduro, Houston, Texas or approved equal.
- A. Purlin and Girts shall be Tuff Span 8F7 Flanged Tube Beam.
 - B. Primary structurals shall be Tuff Span 12F12 or 18F17 Flanged Tube Beam.
 - C. Resin type shall be:
 - _____ Isophthalic Polyester, gray color
 - _____ Vinyl Ester, beige color
 - D. Glass fiber reinforcements shall be continuous and in multi-directional alignment with minimum glass content of 60% of the beam weight.
 - E. Materials shall be fire retardant with Class I Flame Spread Rating, 25 or less per ASTM E-84.

PART THREE: EXECUTION

3.01 Execution

- A. Verify alignment of primary support beams.
- B. Position 8F7 beam on primary beams with flanges upward.
- C. Fasten 8F7 beam with ½" diameter bolt assemblies at each support. Access for fastening 8F7 beams is through field cut 5" diameter access holes. Hole saw is standard tool for cutting access hole.



TuffSpan FRP Structural Shapes

12F12 Flanged Tube

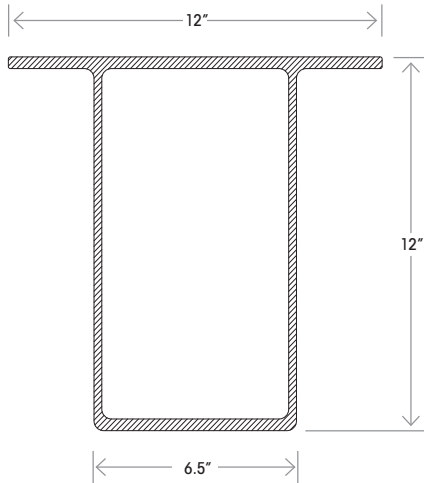

W = 12 lb/ft G = 425,000 psi
 A = 12.64 in² M = 1,225,000 lb-in
 I_{xx} = 284.26 in⁴ r = 3.0572 in
 I_{yy} = 118.31 in⁴ Bf/Bt = 32
 E = 3,800,000 psi K = 1

Span (ft.)	L/D = 120		L/D = 180		L/D = 240		Lth (ft.)	Axial (lbs.)
	1	2	1	2	1	2		
22	451	675	301	675	225	543	7	50850
24	347	567	232	558	174	418	9	44285
26	273	483	182	439	137	329	11	39658
28	219	417	146	351	109	263	13	36176
30	178	363	119	286	89	214	15	33438
32	147	319	98	235	73	176	17	31214
34	122	283	81	196	61	147	19	29361

Beam FOS = 2.5 **1 - Single Span; 2 - Double Span**

Col. FOS = 3

18F17 Flanged Tube

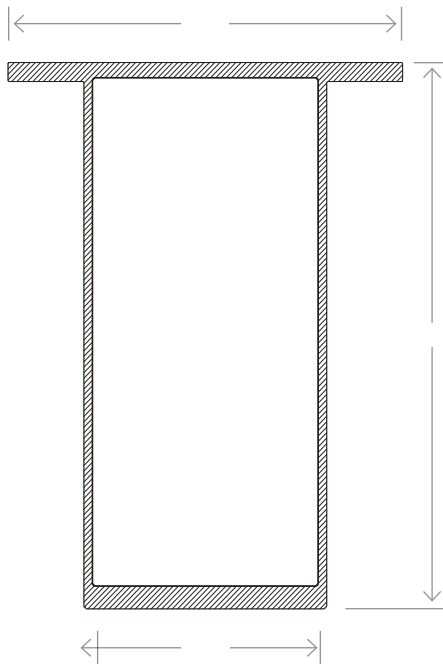

W = 16.75 lb/ft G = 425,000 psi
 A = 22.47 in² M = 2,000,000 lb-in
 I_{xx} = 1197.3 in⁴ r = 3.53 in
 I_{yy} = 279.7 in⁴ Bf/Bt = 20.8
 E = 3,800,000 psi K = 1

Span (ft.)	Allowable Uniform Load (lb/ft) - Unbraced						Column Load (lbs)	
	L/D = 120		L/D = 180		L/D = 240		Lth (ft.)	Axial (lbs.)
	1	2	1	2	1	2		
31	555	555	453	555	339	555	11	72396
32	521	521	411	521	309	521	12	69013
33	490	490	375	490	281	490	13	66041
34	461	461	343	461	257	461	14	63403
35	435	435	314	435	236	435	15	61042
36	412	412	289	412	217	412	16	58914
37	390	390	266	390	200	390	17	56982
38	369	369	246	369	184	369	18	55218
39	341	351	227	351	170	351	19	53600
40	316	333	211	333	158	333	20	52109
41	293	317	196	317	147	317	21	50730
42	273	302	182	302	136	302	22	49448
43	254	288	170	288	127	288	23	48254
44	237	275	158	275	119	275	24	47137
45	222	263	148	263	111	263	25	46091

Beam FOS = 2.5 **1 - Single Span; 2 - Double Span**

Col. FOS = 3

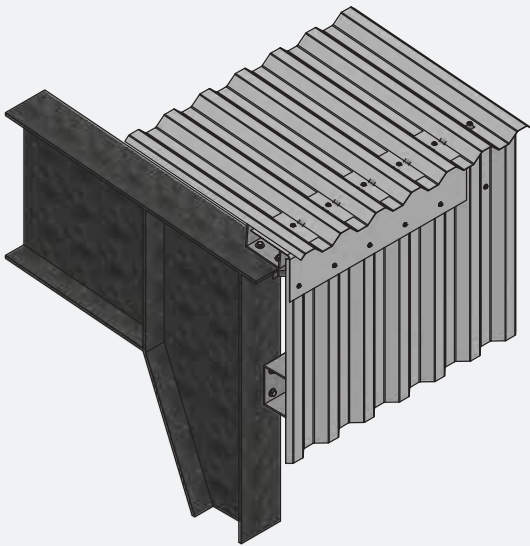

Purlin, Girt, & Cladding Detail at eave

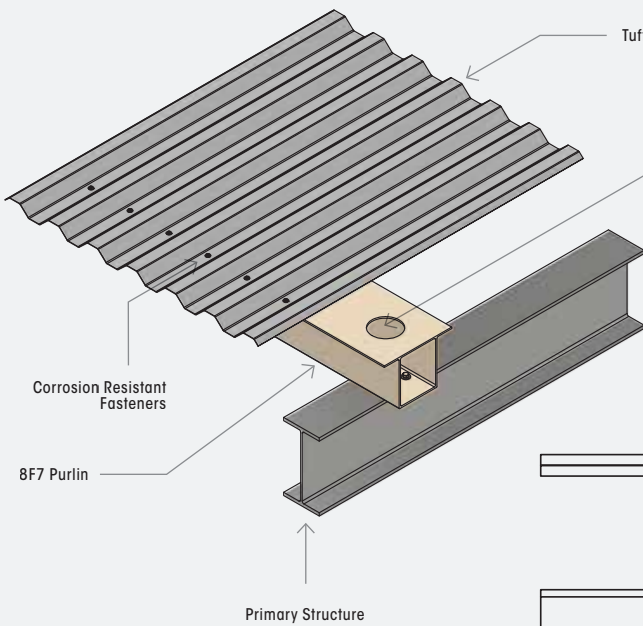
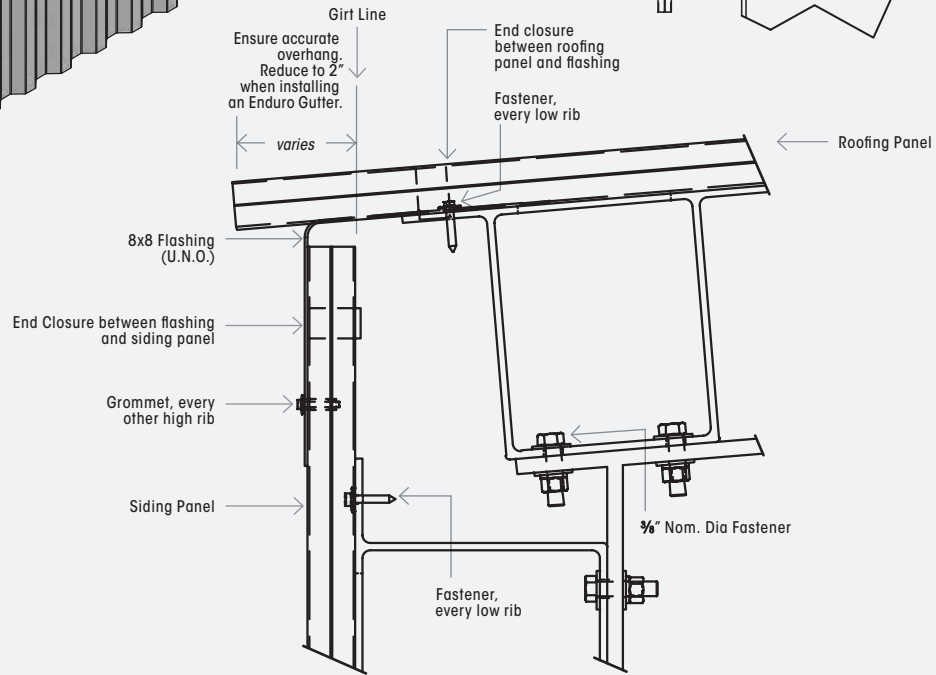

Typical Purlin/Girt and Primary Structure Connection

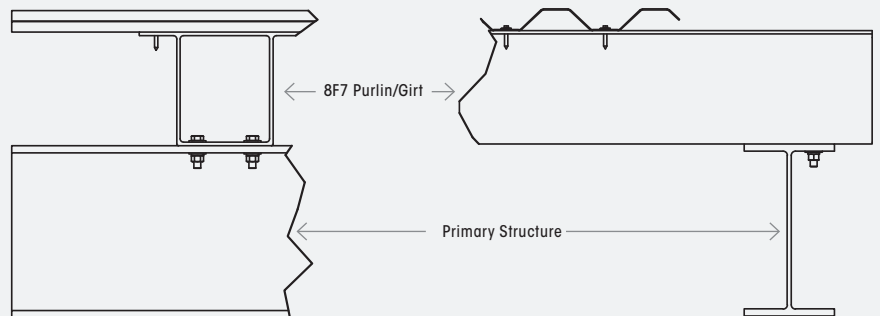



CREATIVE
COMPOSITES
GROUP

Enduro Composites

(800) 231-7271

16602 Central Green Blvd., Houston, TX 77032

[CreativeCompositesGroup.com](https://www.CreativeCompositesGroup.com)

DLR02242026R1
©2026 Creative Composites Group
All Rights Reserved Worldwide

